

Transient Voltage Suppressors (TVS) Data Sheet

Features

- Glass passivated junction
- Low incremental surge resistance
- Excellent clamping capability
- 500W peak pulse power capability at 10/1000 μ s waveform, repetition rate (duty cycle): 0.01%
- Fast response time
- Typical I_R less than 1 μ A above 10V.
- High Temperature soldering guaranteed: 265 $^{\circ}$ C/10 seconds/.375", (9.5mm) lead length, 5lbs (2.3kg) tension
- Plastic package has underwriters laboratory flammability 94V-0
- Meets MSL level 1, per J-STD-020.
- AEC-Q101 qualified (Automotive grade with suffix "Q".)
- Expsemi electronics



Mechanical Data

- Case: JEDEC DO-15 Moulded plastic
- Terminal: Axial leads, solderable per MIL-STD-750, Method 2026
- Polarity: Color band denotes cathode except bi-directional models
- Mounting Position: Any

Applications

- AC/DC power supply
- I/O interface
- Low frequency signal transmission line

Maximum Ratings and Characteristics

Ratings at 25 $^{\circ}$ C ambient temperature unless otherwise specified.

Rating	Symbol	Value	Units
Peak pulse power dissipation at 10/1000 μ s waveform (Note1, Fig.1)	P_{PPM}	Minimum 500	Watts
Peak pulse current of at 10/1000 μ s waveform (Note 1, Fig.3)	I_{PPM}	See Table	Amps
Steady state power dissipation at $T_L=75^{\circ}$ C (Fig.5)	$P_{M(AV)}$	3.0	Watts
Peak forward surge current, 8.3ms single half sine-wave superimposed on rated load, (JEDEC Method) (Note2, Fig.6)	I_{FSM}	70	Amps
Operating junction and Storage Temperature Range.	T_J, T_{STG}	-55 to +175	$^{\circ}$ C
Typical thermal resistance junction to lead	$R_{\theta JL}$	20	$^{\circ}$ C/W
Typical thermal resistance junction to ambient	$R_{\theta JA}$	75	$^{\circ}$ C/W

Notes: 1. Non-repetitive current pulse, per Fig.3 and derated above $T_A=25^{\circ}$ C per Fig.2.

2. 8.3ms single half sine-wave, or equivalent square wave, duty cycle=4 pulses per minutes maximum.

Dimensions (DO-204AC/DO-15)

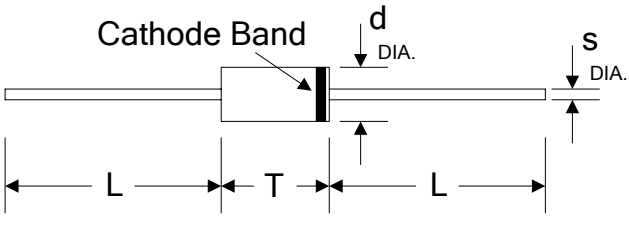
	Symbol	Millimeters		Inches	
		Min.	Max.	Min.	Max.
	L	25.40	-	1.000	-
	T	5.80	7.60	0.230	0.300
	d	2.60	3.60	0.104	0.140
	s	0.71	0.86	0.028	0.034

Electrical Characteristics ($T_A=25^\circ\text{C}$)

Part Number		Reverse Stand-Off Voltage	Breakdown Voltage @ I_T	Test Current	Maximum Clamping Voltage @ I_{PP}	Peak Pulse Current	Reverse Leakage @ V_{RWM}
Unidirectional	Bidirectional	$V_{RWM}(V)$	$V_{BR}(V)$	$I_T(mA)$	$V_C(V)$	$I_{PP}(A)$	$I_R(\mu A)$
SA5.0A	SA5.0CA	5.0	6.40~7.00	10	9.2	55.4	600
SA6.0A	SA6.0CA	6.0	6.67~7.37	10	10.3	49.5	600
SA6.5A	SA6.5CA	6.5	7.22~7.98	10	11.2	45.5	400
SA7.0A	SA7.0CA	7.0	7.78~8.60	10	12.0	42.5	150
SA7.5A	SA7.5CA	7.5	8.33~9.21	1	12.9	39.5	50
SA8.0A	SA8.0CA	8.0	8.89~9.83	1	13.6	37.5	25
SA8.5A	SA8.5CA	8.5	9.44~10.40	1	14.4	35.4	10
SA9.0A	SA9.0CA	9.0	10.00~11.10	1	15.4	33.1	5
SA10A	SA10CA	10.0	11.10~12.30	1	17.0	30.0	3
SA11A	SA11CA	11.0	12.20~13.50	1	18.2	28.0	1
SA12A	SA12CA	12.0	13.30~14.70	1	19.9	25.6	1
SA13A	SA13CA	13.0	14.40~15.90	1	21.5	23.7	1
SA14A	SA14CA	14.0	15.60~17.20	1	23.2	22.0	1
SA15A	SA15CA	15.0	16.70~18.50	1	24.4	20.9	1
SA16A	SA16CA	16.0	17.80~19.70	1	26.0	19.6	1
SA17A	SA17CA	17.0	18.90~20.90	1	27.6	18.5	1
SA18A	SA18CA	18.0	20.00~22.10	1	29.2	17.5	1
SA20A	SA20CA	20.0	22.20~24.50	1	32.4	15.7	1
SA22A	SA22CA	22.0	24.40~26.90	1	35.5	14.4	1
SA24A	SA24CA	24.0	26.70~29.50	1	38.9	13.1	1
SA26A	SA26CA	26.0	28.90~31.90	1	42.1	12.1	1

Electrical Characteristics (T_A=25°C)

Part Number		Reverse Stand-Off Voltage	Breakdown Voltage @I _T	Test Current	Maximum Clamping Voltage @I _{PP}	Peak Pulse Current	Reverse Leakage @V _{RWM}
Unidirectional	Bidirectional	V _{RWM} (V)	V _{BR} (V)	I _T (mA)	V _C (V)	I _{PP} (A)	I _R (μA)
SA28A	SA28CA	28.0	31.10~34.40	1	45.4	11.2	1
SA30A	SA30CA	30.0	33.30~36.80	1	48.4	10.5	1
SA33A	SA33CA	33.0	36.70~40.60	1	53.3	9.6	1
SA36A	SA36CA	36.0	40.00~44.20	1	58.1	8.8	1
SA40A	SA40CA	40.0	44.40~49.10	1	64.5	7.9	1
SA43A	SA43CA	43.0	47.80~52.80	1	69.4	7.3	1
SA45A	SA45CA	45.0	50.00~55.30	1	72.7	7.0	1
SA48A	SA48CA	48.0	53.30~58.90	1	77.4	6.6	1
SA51A	SA51CA	51.0	56.70~62.70	1	82.4	6.2	1
SA54A	SA54CA	54.0	60.00~66.30	1	87.1	5.9	1
SA58A	SA58CA	58.0	64.40~71.20	1	93.6	5.4	1
SA60A	SA60CA	60.0	66.70~73.70	1	96.8	5.3	1
SA64A	SA64CA	64.0	71.10~78.60	1	103.0	5.0	1
SA70A	SA70CA	70.0	77.80~86.00	1	113.0	4.5	1
SA75A	SA75CA	75.0	83.30~92.10	1	121.0	4.2	1
SA78A	SA78CA	78.0	86.70~95.80	1	126.0	4.0	1
SA85A	SA85CA	85.0	94.40~104.00	1	137.0	3.7	1
SA90A	SA90CA	90.0	100.00~111.00	1	146.0	3.5	1
SA100A	SA100CA	100.0	111.00~123.00	1	162.0	3.1	1
SA110A	SA110CA	110.0	122.00~135.00	1	177.0	2.9	1
SA120A	SA120CA	120.0	133.00~147.00	1	193.0	2.6	1
SA130A	SA130CA	130.0	144.00~159.00	1	209.0	2.4	1
SA150A	SA150CA	150.0	167.00~185.00	1	243.0	2.1	1
SA160A	SA160CA	160.0	178.00~197.00	1	259.0	2.0	1
SA170A	SA170CA	170.0	189.00~209.00	1	275.0	1.9	1
SA180A	SA180CA	180.0	201.00~222.00	1	292.0	1.7	1
SA190A	SA190CA	190.0	211.00~233.00	1	308.0	1.6	1
SA200A	SA200CA	200.0	224.00~247.00	1	324.0	1.5	1
SA210A	SA210CA	210.0	237.00~263.00	1	340.0	1.5	1
SA220A	SA220CA	220.0	246.00~272.00	1	356.0	1.4	1

Notes: For bidirectional type having V_{RWM} of 10V and less, the I_R limit is double.

Ratings and Characteristic Curves ($T_A=25^{\circ}\text{C}$ unless otherwise noted)

Figure 1. Peak Pulse Power Rating Curve

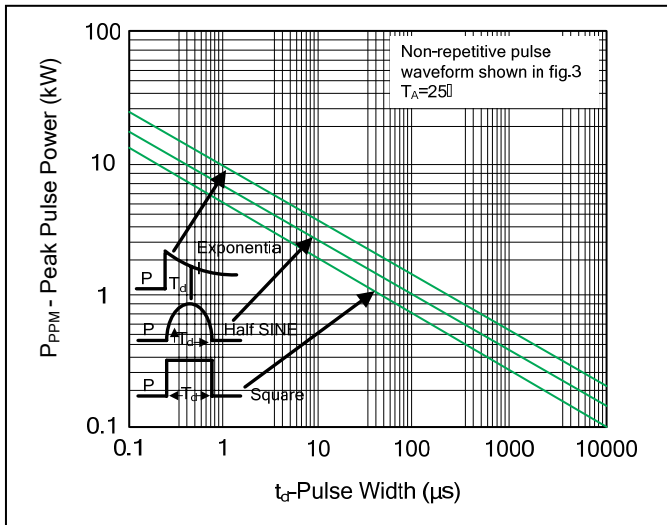

Figure 2. Pulse Derating Curve

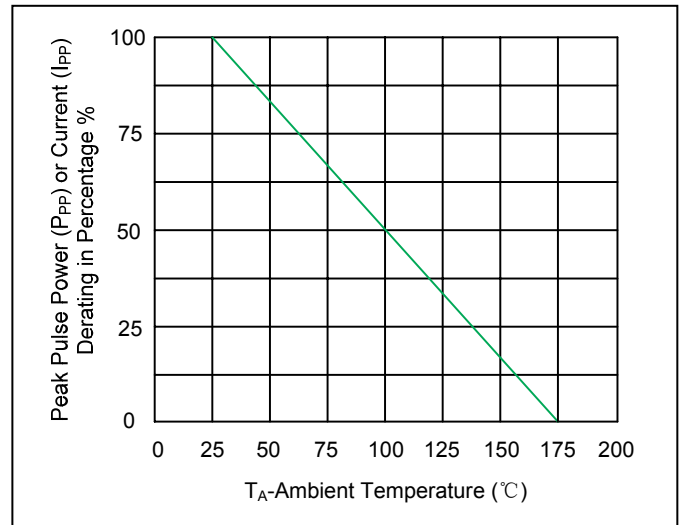

Figure 3. Pulse Waveform

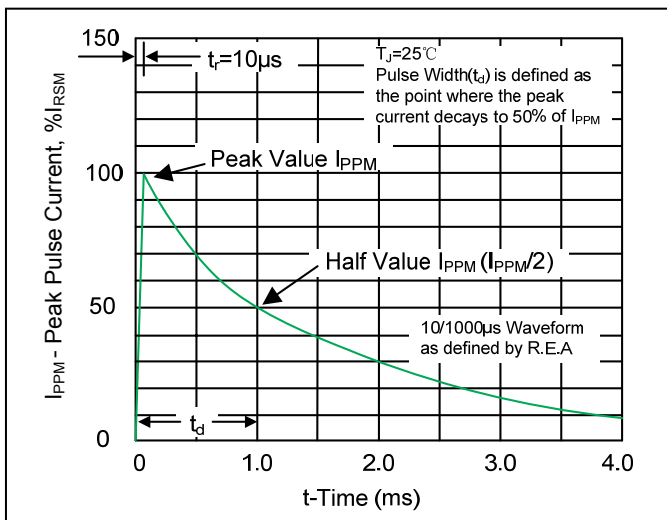

Figure 4. Typical Junction Capacitance

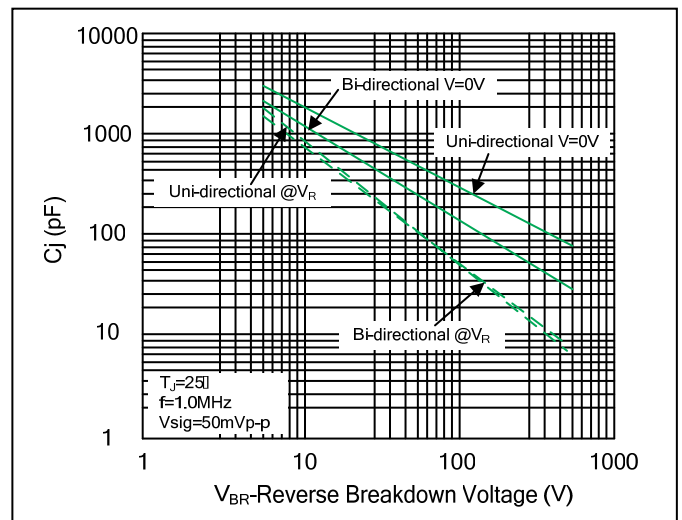

Figure 5. Steady State Power Dissipation Derating Curve

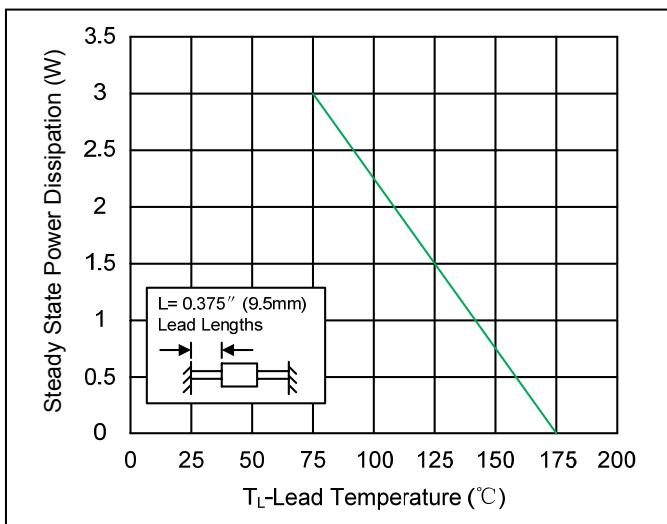
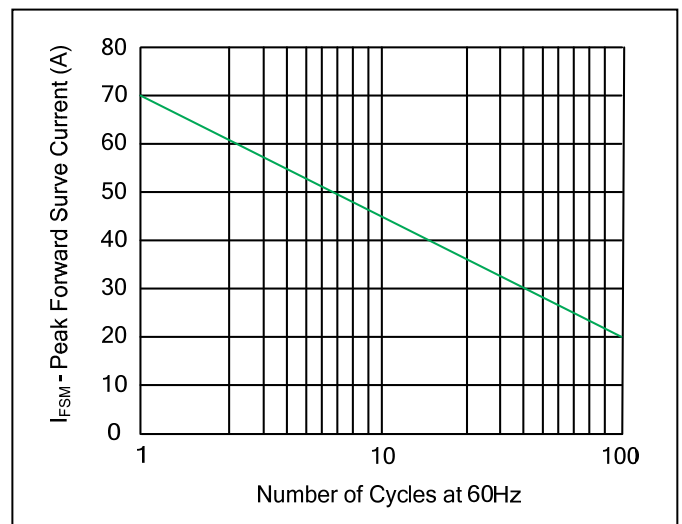

Figure 6. Maximum Non-Repetitive Forward Surge Current Uni-Directional Only



Recommended Soldering Conditions

Soldering Parameters

Reflow Condition		Lead-free assembly
Pre Heat	- Temperature Min ($T_{s(min)}$)	150°C
	- Temperature Max ($T_{s(max)}$)	200°C
	- Time (min to max) (t_s)	60 – 180 secs
Average ramp up rate (Liquidus Temp (T_A) to peak)		3°C/second max
$T_{s(max)}$ to T_A - Ramp-up Rate		3°C/second max
Reflow	- Temperature (T_A) (Liquidus)	217°C
	- Time (min to max) (t_s)	60 – 150 seconds
Peak Temperature (T_p)		260 ^{+0/-5} °C
Time within 5°C of actual peak Temperature (t_p)		20 – 40 seconds
Ramp-down Rate		6°C/second max
Time 25°C to peak Temperature (T_p)		8 minutes Max.
Do not exceed		260°C

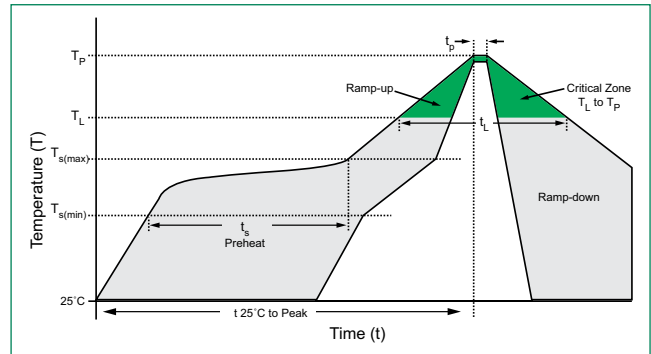

Flow/Wave Soldering (Solder Dipping)

Peak Temperature :	265°C
Dipping Time :	10 seconds
Soldering :	1 time

Physical Specifications

Case	JEDEC DO-204AC (DO-15) molded plastic body over passivated junction.
Polarity	Color band denotes the cathode except Bipolar.
Terminal	Matte Tin axial leads, solderable per JESD22-B102.

Environmental Specifications

High Temp. Storage	JESD22-A103
HTRB	JESD22-A108
Temperature Cycling	JESD22-A104
H3TRB	JESD22-A101
RSH	JESD22-B106

Dimensions

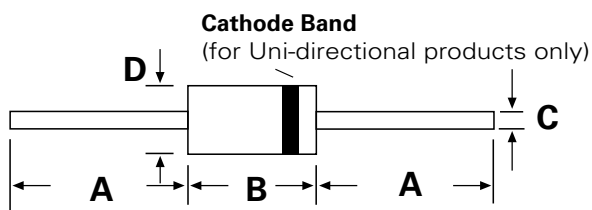

DO-204AC (DO-15)

Dimensions	Inches		Millimeters	
	Min	Max	Min	Max
A	1.000	-	25.40	-
B	0.230	0.300	5.80	7.60
C	0.028	0.034	0.71	0.86
D	0.104	0.140	2.60	3.60

Part Numbering System

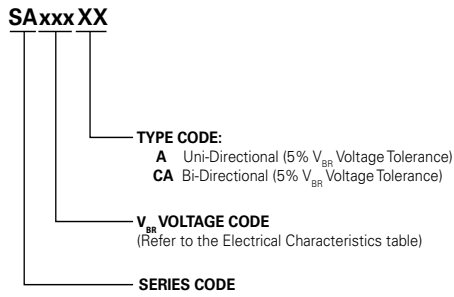

Part Marking System

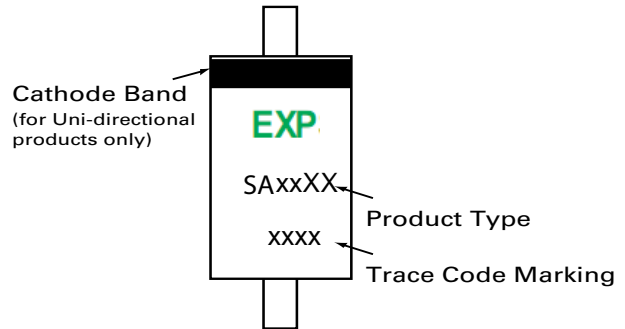

Packaging

Part Number	Component Package	Quantity	Packaging Option	Packaging Specification
SAxxxXX	DO-204AC	2000	Tape & Reel	EIA STD RS-296

Tape and Reel Specification

Tape	Symbol	Dimension (mm)
	A	5.0±0.5
	B	53.0±1.0
	Z	1.2Max.
	T	6.0±0.4
	E	0.8Max.
	L1-L2	1.0Max.